

Model 1150

Instruction Manual

CO Reactor

Part Number 13392

20Dec2007

© 2007 Thermo Fisher Scientific Inc. All rights reserved.

Specifications, terms and pricing are subject to change. Not all products are available in all countries. Please consult your local sales representative for details.

Thermo Fisher Scientific
Air Quality Instruments
27 Forge Parkway
Franklin, MA 02038
1-508-520-0430
www.thermo.com/aqi

WEEE Compliance

This product is required to comply with the European Union's Waste Electrical & Electronic Equipment (WEEE) Directive 2002/96/EC. It is marked with the following symbol:



Thermo Fisher Scientific has contracted with one or more recycling/disposal companies in each EU Member State, and this product should be disposed of or recycled through them. Further information on Thermo Fisher Scientific's compliance with these Directives, the recyclers in your country, and information on Thermo Fisher Scientific products which may assist the detection of substances subject to the RoHS Directive are available at: www.thermo.com/WEEERoHS.

TABLE OF CONTENTS

CHAPTER 1 INTRODUCTION.....	1-1
Principals of Operation	1-1
Specifications	1-2
CHAPTER 2 INSTALLATION.....	2-1
Unpacking.....	2-1
Installation Procedure	2-2
System Plumbing Connections	2-2
Startup Procedure	2-3
CHAPTER 3 OPERATION.....	3-1
CO-Reactor	3-1
Temperature Controller.....	3-1
CHAPTER 4 PREVENTIVE MAINTENANCE.....	4-1
Safety Precautions	4-1
Replacement Parts List.....	4-1
Flow Leak Check	4-2
CHAPTER 5 TROUBLESHOOTING.....	5-1
Troubleshooting Guide.....	5-1
APPENDIX A WARRANTY.....	A-1
APPENDIX B SCHEMATICS	B-1
Electrical Wiring.....	B-1
Plumbing Diagram.....	B-2

LIST OF ILLUSTRATIONS

Figure	Page
2-1. Model 1150 Front Panel	2-1
2-2. Model 1150 Rear Panel	2-2
2-3. Model 1150 Internal Plumbing	2-3

LIST OF TABLES

Table	Page
4-1. Replacement Parts	4-1

CHAPTER 1

INTRODUCTION

Thermo Environmental Instruments is pleased to provide the Model 1150 CO Reactor. We are committed to the manufacture of instruments exhibiting high standards of quality, performance, and workmanship. TEI service and support personnel are available to provide assistance with any questions or problems that may arise in the use of this CO-Reactor.

The Model 1150 CO Reactor removes Carbon Monoxide (CO) and Hydrocarbons from clean, dry, oil free filtered instrument air. The output of the Model 1150 can be used for dilution or zero air for the Model 48 Series of Carbon Monoxide analyzers or for the Model 51 and Model 55C Hydrocarbon analyzers.

PRINCIPLE OF OPERATION

The Model 1150 is utilized to provide a Dilution or Extractive Continuous Emission Monitoring System as a means of eliminating most of the Carbon Monoxide and Hydrocarbons in a clean dry air supply. Two converters are used to convert the CO gas to Carbon Dioxide (CO₂). This provides for the efficient catalytic conversion of Carbon Monoxide and Hydrocarbons. Each converter is controlled from a separate temperature controller. Normally the temperature setting for the individual converters are 250°C for the first converter (left controller on the front panel) and 325°C for the second converter (right controller on the front panel). The temperature settings may be adjusted if the converter needs the extra temperature for converting the CO to CO₂. The first CO converter is a pre-converter for the initial entry of the air flow to the Model 1150. The second reactor will convert the balance of the CO to CO₂.

SPECIFICATIONS

Operating temperature	60 to 80 °F
Power Requirements	115/230 Volts \pm 10%, single -phase, 50/60 Hz, 200 Watts
Maximum Flow Capacity	20 LPM
Physical Dimensions	16 7/8" W x 7" H x 15 3/16" L
Weight	21 lbs.

Any alteration, modification, or republication of this instruction manual or any alteration or modification to the Thermo Environmental Instrument product without the express written consent of Thermo Environmental Instruments Inc. is expressly prohibited, nullifies our warranty obligations, and bars our liability for any damages deriving therefrom.

CHAPTER 2 INSTALLATION

The installation of the Model 1150 includes unpacking the CO Reactor, connecting lines to the CO Reactor, and initial installation for the Model 1150.

UNPACKING

The Model 1150 is shipped complete in one container. If, upon receipt of the CO Reactor, there is obvious damage to the shipping container, notify the carrier immediately and hold for inspection. The carrier, and not Thermo Environmental Instruments Inc., is responsible for any damage incurred during shipment. Follow the procedure below to unpack and inspect the CO Reactor.

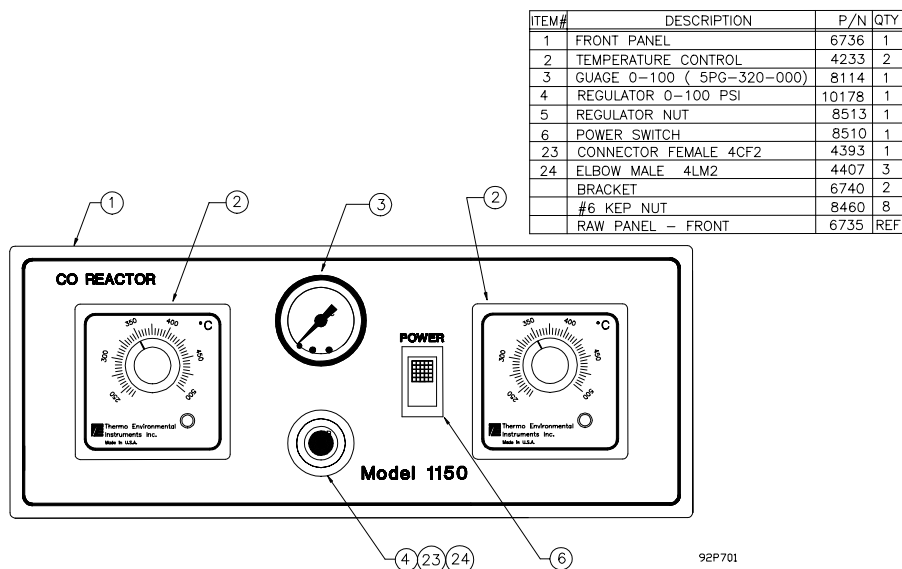

Figure 2-1. Model 1150 Front Panel

1. Remove the CO Reactor unit from the shipping container if the unit was packed in a container and set it on a table or bench that allows easy access to both the front and rear of the instrument.
2. Remove the CO Reactor cover to expose the internal components.
3. Remove any internal packing material.
4. Check for possible damage during shipment.
5. Check all connectors to see if they are firmly attached.
6. Check for proper transformer configuration.
7. Re-install the CO Reactor cover.

INSTALLATION PROCEDURE

Before connecting any power or lines to the rear of the reactor unit, refer to system documentation, if supplied, for any details which may not be included in this manual. Check the Purchase Order packing slip to ensure the unit was ordered with the right configuration. If any of the information is incorrect, contact the Sales Representative from which the unit was purchased from or call a Sales Representative at Thermo Environmental Instruments at 508-520-0430. Information in the system documentation will refer to more detailed wire connections and plumbing diagrams. System documentation will only be issued if the unit is supplied as a component of a larger system.

Before power up of the Model 1150 CO Reactor, make sure the proper transformer configuration is correct for the proper outlet. Identify the rear panel for appropriate outlet labeling. The transformer is marked accordingly for either 110 AC or 220 AC.

PLUMBING

Connections for the various lines to the rear panel of the Model 1150 are illustrated in Figure 2-2.. If the unit was purchased with a system, or if the customer requested system documentation, refer to those appropriate documents or drawings for proper connections. All tubing connected to the CO Reactor is made of Teflon®. Once proper configuration is completed and checked, the startup procedure may be initiated.

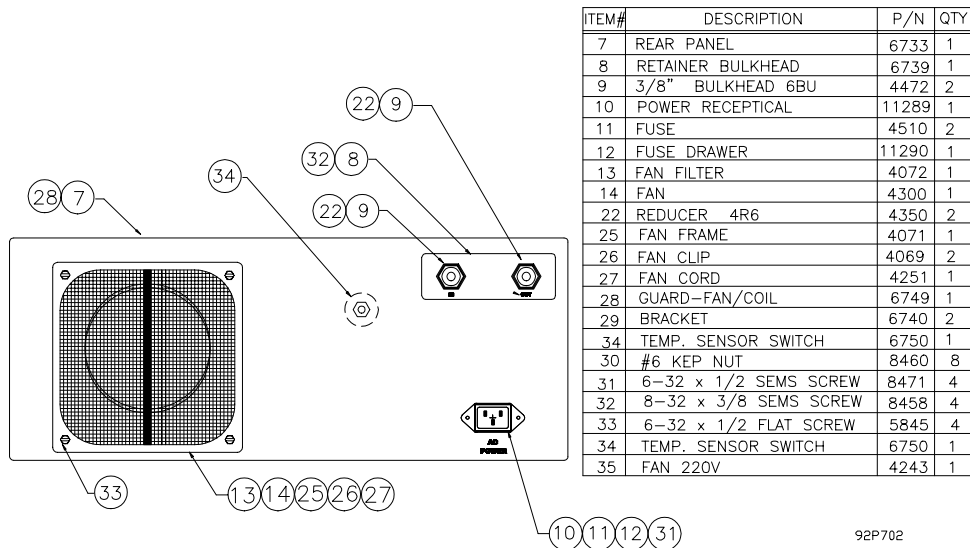

Figure 2-2 Model 1150 Rear Panel

STARTUP PROCEDURE

1. The Model 1150 is now ready to be installed either in a rack assembly or for test bench purposes. With the unit placed in a secured location, the lines to the unit can be connected. Figure 2-3 illustrates the internal plumbing connections of the Model 1150. Only two lines are needed for connection from the rear of the Model 1150 CO Reactor unit. One line is for the input air and the other is for the output air which is converted from CO to CO₂.
2. Connect the power cord to the rear of the unit and turn the power ON.
3. Check to make sure the power switch light is ON.
4. Monitor the temperature indicator lights. Make sure that the temperature adjust knobs are set to 275°F and 325°F since the knobs may have turned during shipment.
5. When the unit has run for 30 minutes, turn the temperature control knobs and check to see if the neon indicator lights are cycling.

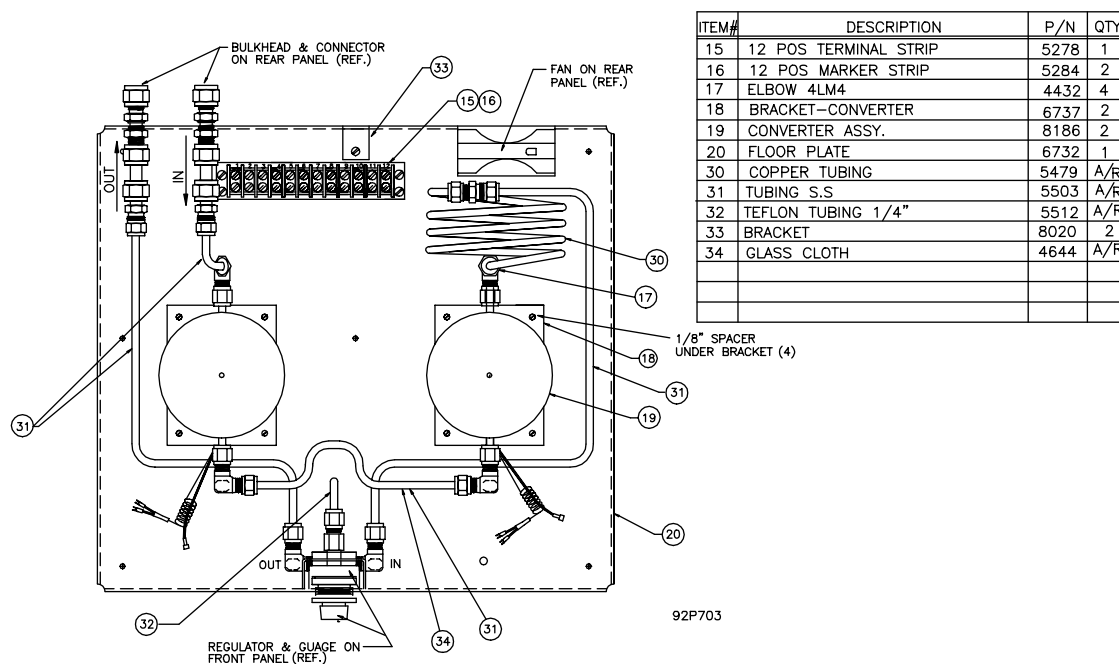

Figure 2-3 Model 1150 Internal Plumbing

The inlet line to the CO-Reactor Unit from an air dryer or other type of zero air scrubber unit should be properly labeled and connected to the correct port fitting. A pressure of 80 to 100 psig of clean zero air is supplied to the air inlet port of the Model 1150.

CHAPTER 3 OPERATION

In order to fully understand the operation of the Model 1150, a general knowledge of the flow and subassemblies is recommended. A better understanding of the components themselves will allow the user to correctly and more efficiently change parts or subassemblies.

CO-REACTOR

The co-reactor converts CO gas to CO₂. The elevated air temperature works in conjunction with the converter. As air passes through the converter, oxygen present in the air is combined with CO gases. The packing material in the converter acts as a catalyst.

TEMPERATURE CONTROLLER

A temperature controller is used to maintain the temperature of each reactor. It turns the electrical power on when the temperature falls and off when the temperature rises above the set point temperature. It has a fail-safe mechanism that turns the power off if the thermo-couple is broken. The controller is adjusted to the proper temperature at the factory; however, readjustment may become necessary. This can be accomplished by turning the knob on the temperature controller to select the desired value.

CHAPTER 4

PREVENTIVE MAINTENANCE

This chapter describes the periodic maintenance procedures that should be performed on the Model 1150 to ensure proper, uninterrupted operation. Components have a limited life expectancy, so periodic checks and replacement of certain components or devices may be necessary from time to time.

SAFETY PRECAUTIONS

Some internal components may be damaged by the discharge of static electricity. To avoid damaging internal components, follow these precautions when performing any service procedure:

- Wear an antistatic wrist strap that is properly connected to earth ground (note that when the analyzer is unplugged, the chassis is not at earth ground).
- If an antistatic wrist strap is not available, be sure to touch a grounded metal object before touching any internal components.
- Carefully observe the instructions in each procedure.
- Remove the power cord from the unit when any of the assemblies are to be replaced.

REPLACEMENT PARTS LIST

Table 4-1 lists the part numbers of the major components in the Model 1150.

Table 4-1. Replacement Parts

Part number	Description	Quantity
4233	Temperature Controller	2
8106	Regulator 0-100 psig	1
8114	Pressure Gauge 0-100 psig	1
4072	Fan Filter Element	1
4510	Fuse 3 AMP	1
8186	Reactor Assembly	2

Chapter 4 Preventative Maintenance

Keeping spare parts on hand will reduce the amount of time the unit or system is down when repairs are necessary.

NOTE: When keeping reactor assembly in stock as a spare part, it is important to keep the end openings sealed. They should be opened immediately prior to installation.

FLOW LEAK CHECK

This procedure enables the user to thoroughly check the unit for leaks. Leak checking would be only conducted if the Model 1150 is suspected of inconsistent air flow from the CO Reactor.

NOTE: Before performing any leak checks, the unit should be unplugged from the AC outlet. Wait for the converters to cool to room temperature (one hour should be sufficient time to cool the converters when zero air is passed through them).

Attach a pressure gauge to the outlet port of the Model 1150. Connect a shut off valve from the compressed air to the inlet port of the Model 1150. Apply approximately 50 psig of pressure flow through the line and then shut off the valve to keep the pressure suspended in the line of the CO-Reactor unit. Wait for about two minutes and monitor the pressure reading to see if the reading of the pressure drops. If the valve was shut off at 50 psig and stays at or above 48 psig for two minutes, the line is leak tight. If the pressure goes below and gradually falls to zero, then the line either needs to be replaced or the fittings are not tight.

If a leak can be heard, use a leak check solution and apply to the area where the leak is heard. The solution will bubble if the solution is applied in the right place. There are two common possible solutions with a leak problem. Either the fitting is not tight or the line needs to be replaced. Another possible leak problem could be caused by a leaky component such as a regulator, gauge, or tubing connector.

CHAPTER 5

TROUBLESHOOTING

The Model 1150 has been designed to achieve a high level of reliability. Only premium components are used, thus complete failure is rare. In the event of problems or failure, the troubleshooting guidelines presented in this chapter should help in isolating the fault(s). The Service Department at Thermo Environmental can be consulted at (508) 520-0430 in the event of problems. In any correspondence with the factory, please note the serial number of the controller unit.

CAUTION: Some internal components can be damaged by small amounts of static electricity. A properly grounded antistatic wrist strap must be worn while handling any internal component.

TROUBLESHOOTING GUIDE

MALFUNCTION	POSSIBLE CAUSE	ACTION
Does not start up.	No Power	Check that the unit is plugged into the power source (115 or 220 volts) Check unit fuse
	Temperature Controller	Replace the temperature controller.
Temperature will not turn on.	Thermo-Couple	Disconnect the Thermo-couple leads and measure.
	Dirty Air Supply	Inspect for high levels of hydrocarbons (compressor lube oil carry over) and/or CO at the compressor air source.
High CO readings.		

SERVICE LOCATIONS

For additional assistance, Thermo Environmental Instruments provides customer service from the following locations:

Thermo Environmental Instruments Inc.
8 West Forge Parkway
Franklin, Massachusetts 02038
Telephone: (508) 520-0430
Facsimile: (508) 520-1460

Thermo Environmental Instruments Inc.
325 E. Arrow Hwy. #506
San Dimas, California 91773
Telephone: (909) 394-2373
Facsimile: (909) 394-2367

Thermo Environmental Instruments has additional service personnel located throughout the country. Contact either of the above service centers for more information.

If equipment must be returned, obtain an authorization number from the service center to speed response. This number must appear on the outside of the shipping carton.

Appendix A

Warranty

Seller warrants that the Products will operate or perform substantially in conformance with Seller's published specifications and be free from defects in material and workmanship, when subjected to normal, proper and intended usage by properly trained personnel, for the period of time set forth in the product documentation, published specifications or package inserts. If a period of time is not specified in Seller's product documentation, published specifications or package inserts, the warranty period shall be one (1) year from the date of shipment to Buyer for equipment and ninety (90) days for all other products (the "Warranty Period"). Seller agrees during the Warranty Period, to repair or replace, at Seller's option, defective Products so as to cause the same to operate in substantial conformance with said published specifications; provided that (a) Buyer shall promptly notify Seller in writing upon the discovery of any defect, which notice shall include the product model and serial number (if applicable) and details of the warranty claim; (b) after Seller's review, Seller will provide Buyer with service data and/or a Return Material Authorization ("RMA"), which may include biohazard decontamination procedures and other product-specific handling instructions; and (c) then, if applicable, Buyer may return the defective Products to Seller with all costs prepaid by Buyer. Replacement parts may be new or refurbished, at the election of Seller. All replaced parts shall become the property of Seller. Shipment to Buyer of repaired or replacement Products shall be made in accordance with the Delivery provisions of the Seller's Terms and Conditions of Sale. Consumables, including but not limited to lamps, fuses, batteries, bulbs and other such expendable items, are expressly excluded from the warranty under this warranty.

Notwithstanding the foregoing, Products supplied by Seller that are obtained by Seller from an original manufacturer or third party supplier are not warranted by Seller, but Seller agrees to assign to Buyer any warranty rights in such Product that Seller may have from the original manufacturer or third party supplier, to the extent such assignment is allowed by such original manufacturer or third party supplier.

In no event shall Seller have any obligation to make repairs, replacements or corrections required, in whole or in part, as the result of (i) normal wear and tear, (ii) accident, disaster or event of force majeure, (iii) misuse, fault or negligence of or by Buyer, (iv) use of the Products in a manner for which

they were not designed, (v) causes external to the Products such as, but not limited to, power failure or electrical power surges, (vi) improper storage and handling of the Products or (vii) use of the Products in combination with equipment or software not supplied by Seller. If Seller determines that Products for which Buyer has requested warranty services are not covered by the warranty hereunder, Buyer shall pay or reimburse Seller for all costs of investigating and responding to such request at Seller's then prevailing time and materials rates. If Seller provides repair services or replacement parts that are not covered by the warranty provided in this warranty, Buyer shall pay Seller therefor at Seller's then prevailing time and materials rates. ANY INSTALLATION, MAINTENANCE, REPAIR, SERVICE, RELOCATION OR ALTERATION TO OR OF, OR OTHER TAMPERING WITH, THE PRODUCTS PERFORMED BY ANY PERSON OR ENTITY OTHER THAN SELLER WITHOUT SELLER'S PRIOR WRITTEN APPROVAL, OR ANY USE OF REPLACEMENT PARTS NOT SUPPLIED BY SELLER, SHALL IMMEDIATELY VOID AND CANCEL ALL WARRANTIES WITH RESPECT TO THE AFFECTED PRODUCTS.

THE OBLIGATIONS CREATED BY THIS WARRANTY STATEMENT TO REPAIR OR REPLACE A DEFECTIVE PRODUCT SHALL BE THE SOLE REMEDY OF BUYER IN THE EVENT OF A DEFECTIVE PRODUCT. EXCEPT AS EXPRESSLY PROVIDED IN THIS WARRANTY STATEMENT, SELLER DISCLAIMS ALL OTHER WARRANTIES, WHETHER EXPRESS OR IMPLIED, ORAL OR WRITTEN, WITH RESPECT TO THE PRODUCTS, INCLUDING WITHOUT LIMITATION ALL IMPLIED WARRANTIES OF MERCHANTABILITY OR FITNESS FOR ANY PARTICULAR PURPOSE. SELLER DOES NOT WARRANT THAT THE PRODUCTS ARE ERROR-FREE OR WILL ACCOMPLISH ANY PARTICULAR RESULT.

APPENDIX B SCHEMATICS

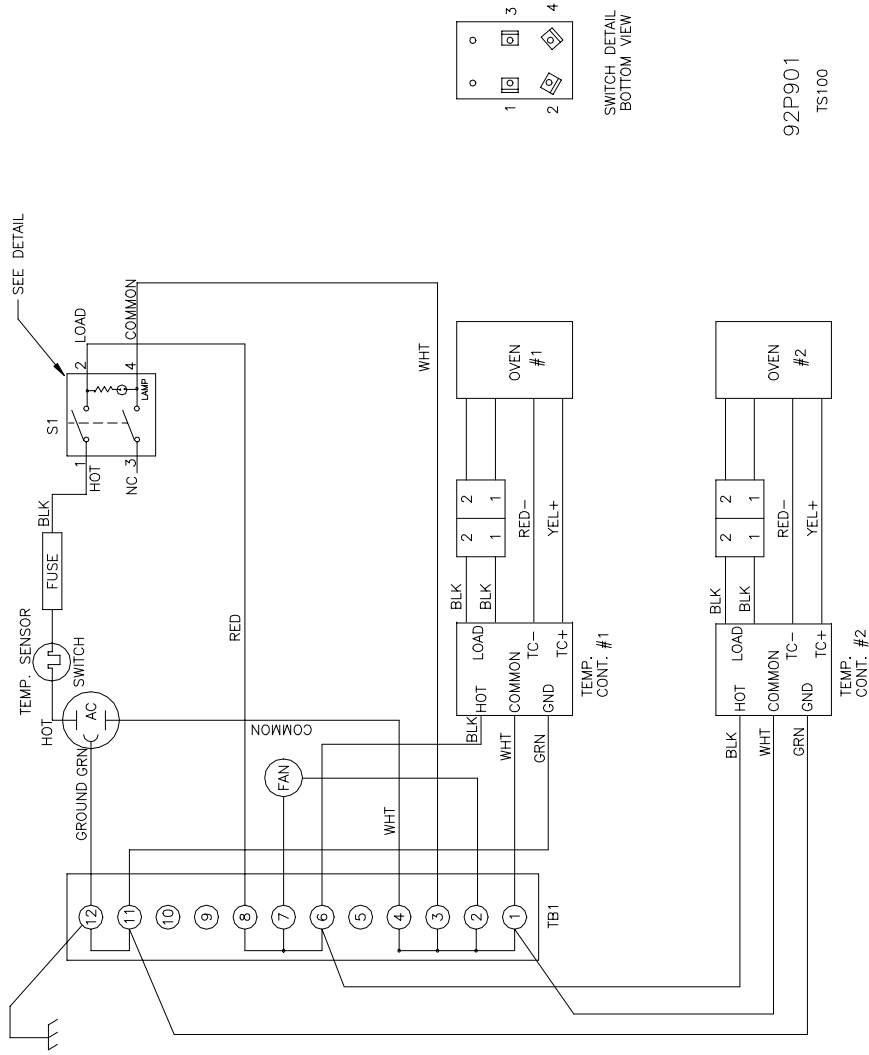

WIRING DIAGRAM

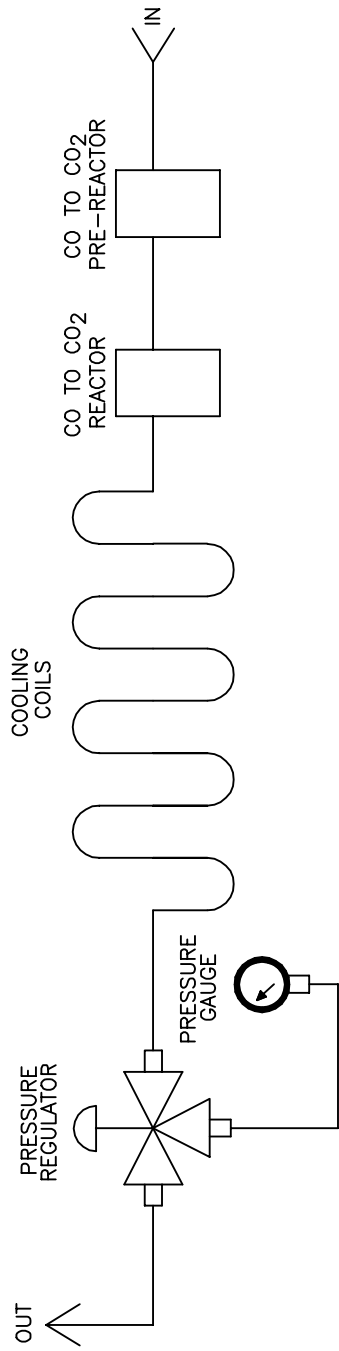

92PE01